



Area and Circumference of Circles



← REVISE THIS TOPIC

1 A circle has a radius of 8 cm.

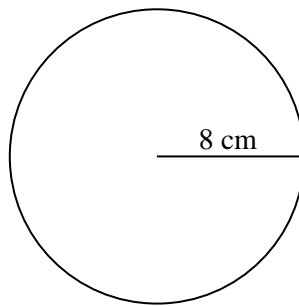

(a) Work out the area of the circle.
Give your answer to 1 decimal place.

$$\pi \times 8^2 = 201.0619298$$

$$\underline{\hspace{1cm} 201.1 \hspace{1cm}} \text{ cm}^2$$

(2)

(b) Work out the circumference of the circle.
Give your answer to 1 decimal place.

$$\pi \times 16 = 50.26548246$$

$$\underline{\hspace{1cm} 50.3 \hspace{1cm}} \text{ cm}$$

(2)

(Total for Question 1 is 4 marks)



2 A circle has a diameter of 20 cm.

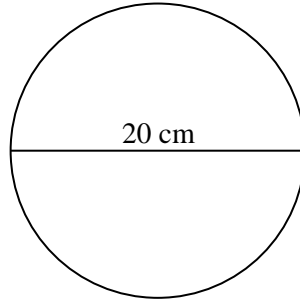

- (a) Work out the area of the circle.
Give your answer to 1 decimal place.

$$\pi \times 10^2 = 314.1592654$$

$$\underline{\underline{314.2}} \text{ cm}^2$$

(2)

- (b) Work out the circumference of the circle.
Give your answer to 1 decimal place.

$$\pi \times 20 = 62.83185307$$

$$\underline{\underline{62.8}} \text{ cm}$$

(2)

(Total for Question 2 is 4 marks)



3 A circle has a radius of 7 cm.

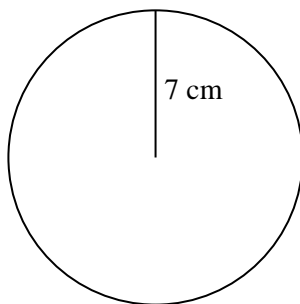

(a) Work out the area of the circle.
Give your answer in terms of π

$$\pi \times 7^2 = 49\pi$$

$$\frac{49\pi}{(2)} \text{ cm}^2$$

(b) Work out the circumference of the circle.
Give your answer in terms of π

$$\pi \times 14 = 14\pi$$

$$\frac{14\pi}{(2)} \text{ cm}$$

(Total for Question 3 is 4 marks)



4 A circle has a diameter of 12 cm.

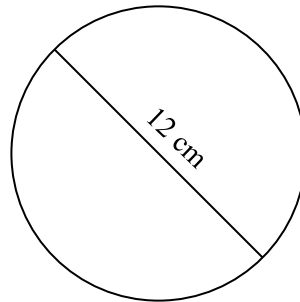

- (a) Work out the area of the circle.
Give your answer in terms of π

$$\pi \times 6^2 = 36\pi$$

$$\text{..... } 36\pi \text{ cm}^2$$

(2)

- (b) Work out the circumference of the circle.
Give your answer in terms of π

$$\pi \times 12 = 12\pi$$

$$\text{..... } 12\pi \text{ cm}$$

(2)

(Total for Question 4 is 4 marks)



5 Here is a semicircle with a diameter of 30 cm.

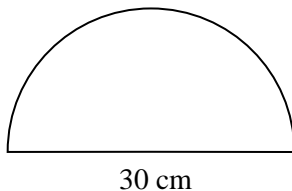

- (a) Work out the area of the semicircle.
Give your answer to 1 decimal place.

$$\pi \times 15^2 = 706.8583471$$

$$706.8... \div 2 = 353.4291735$$

$$\underline{\hspace{1.5cm} 353.4 \hspace{1.5cm}} \text{ cm}^2$$

(3)

- (b) Work out the perimeter of the semicircle.
Give your answer to 1 decimal place.

$$\pi \times 30 = 94.24777961$$

$$94.2... \div 2 = 47.1238898$$

$$47.1... + 30 = 77.1238898$$

$$\underline{\hspace{1.5cm} 77.1 \hspace{1.5cm}} \text{ cm}$$

(3)

(Total for Question 5 is 6 marks)



6 Here is a quarter circle with a radius of 9 cm.

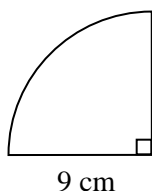

(a) Work out the area of the quarter circle.
Give your answer to 1 decimal place.

$$\pi \times 9^2 = 254.4690049$$

$$254.4... \div 4 = 63.61725124$$

$$\underline{\hspace{10em} 63.6 \hspace{10em}} \text{ cm}^2$$

(3)

(b) Work out the perimeter of the quarter circle.
Give your answer to 1 decimal place.

$$\pi \times 18 = 56.54866776$$

$$56.5... \div 4 = 14.13716694$$

$$14.1... + 9 + 9 = 32.13716694$$

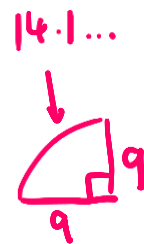

$$\underline{\hspace{10em} 32.1 \hspace{10em}} \text{ cm}$$

(3)

(Total for Question 6 is 6 marks)



7 Here is a semicircle with a diameter of 8 m.

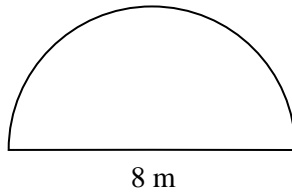

- (a) Work out the area of the semicircle.
Give your answer in terms of π

$$\pi \times 4^2 = 16\pi$$

$$16\pi \div 2 = 8\pi$$

$$\frac{8\pi}{(3)} \text{ m}^2$$

- (b) Work out the perimeter of the semicircle.
Give your answer in terms of π

$$\pi \times 8 = 8\pi$$

$$8\pi \div 2 = 4\pi$$

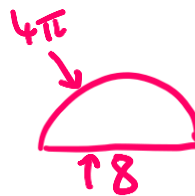

$$\frac{4\pi + 8}{(3)} \text{ m}$$

(Total for Question 7 is 6 marks)



8 The diagram below shows a circular shaped garden with a radius of 7.5 m

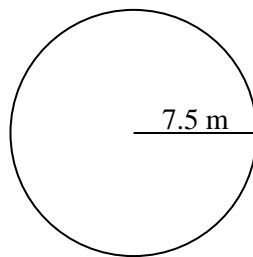

- (a) A gardener plans to cover the garden in grass seed.
 A box of grass seed will cover 40 square metres of the garden.
 Work out how many boxes of grass seed the gardener will need.

$$\pi \times 7.5^2 = 176.7145868 \text{ m}^2$$

$$176.714... \div 40 = 4.417864669$$

5 boxes
(3)

- (b) The gardener also wishes to put a fence around the outside of the garden.
 The fencing costs £30 per metre.
 Work out the total cost of putting a fence around the out of the garden.
 Give your answer to the nearest pound.

$$\pi \times 15 = 47.1238898 \text{ m}$$

$$47.1... \times \pounds 30 = \pounds 1413.716694$$

£ 1414
(3)

(Total for Question 8 is 6 marks)



9 Here is circle **A** and circle **B**.

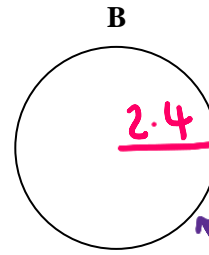
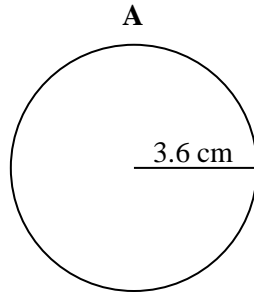

↑ diameter = 4.8

Radius of circle **A** : Radius of circle **B** = 3 : 2

Work out the circumference of circle **B**
Give your answer to 1 decimal place.

$$\begin{array}{c} \times 1.2 \quad \left[\begin{array}{c} 3 : 2 \\ \rightarrow 3.6 : 2.4 \leftarrow \end{array} \right] \times 1.2 \end{array}$$

$$\begin{aligned} &\pi \times 4.8 \\ &= 15.07964474 \end{aligned}$$

15.1

..... cm

(Total for Question 9 is 3 marks)

10 The circumference of a circle is 200 cm.
Work out the radius of the circle.
Give your answer to 2 decimal places.

$$\begin{aligned} 200 \div \pi &= 63.66197724 \text{ (diameter)} \\ 63.6\dots \div 2 &= 31.83098862 \text{ (radius)} \end{aligned}$$

31.83

..... cm

(Total for Question 10 is 3 marks)



11 Here is a circular wire with a radius of 10 cm.

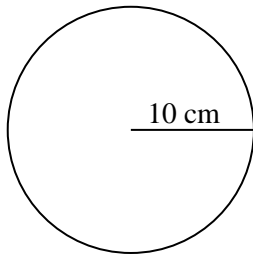

The circular wire is bent to form an equilateral triangle.

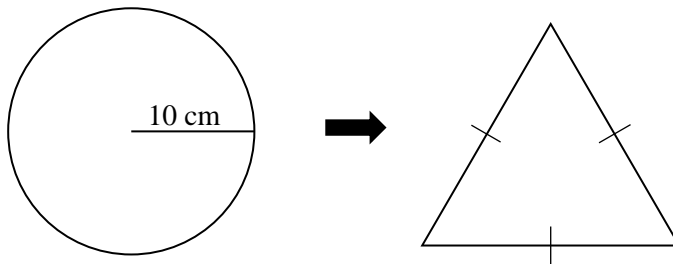

(a) Work out the length of one side of the equilateral triangle.
Give your answer to 1 decimal place.

$$\pi \times 20 = 62.83185307$$

$$62.8... \div 3 = 20.94395102$$

$$\text{.....} \underline{20.9} \text{..... cm}$$

(3)



(b) Instead, the circular wire is bent into the shape of a square.

What does this mean about the length of one side of the square?

Tick **one** box.

It is more than the answer to part (a)

It is the same the answer to part (a)

It is less than the answer to part (a)

(1)

(Total for Question 11 is 4 marks)

12 The shaded region below is made from two circles.

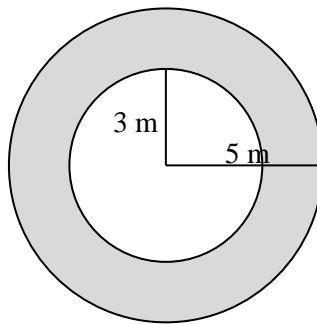

The radius of the smaller circle is 3 m.

The radius of the larger circle is 5 m.

Calculate the area of the shaded region.

$$\begin{aligned}
 \pi \times 5^2 &= 78.53981634 \\
 \pi \times 3^2 &= 28.27433388 \\
 78.53981634 - 28.27433388 &= 50.26548246
 \end{aligned}$$

..... 50.3 m²

(3)

(Total for Question 12 is 3 marks)



13 A running track is made from two straight sections and two semicircles.

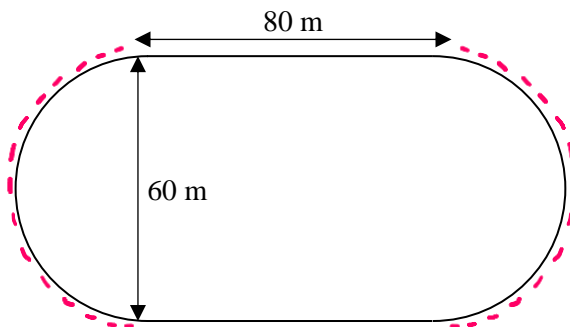

The straight sections are 80 m long.
The semicircles both have a diameter of 60 m.

- (a) Work out the total length of the running track.
Give your answer to the nearest metre.

(and) gives π

$$\pi \times 60 = 188.4955592$$

$$188.4... + 80 + 80 = 348.495...$$

$$\underline{\hspace{10em} 348 \hspace{10em}} \text{ m}$$

(3)

- (b) The inside of the running track is covered with grass.
Work out the area of the grass on the inside of the running track.
Give your answer to 1 decimal place.

Circle: $\pi \times 30^2 = 2827.433388$

Rectangle: $60 \times 80 = 4800$

$$4800 + 2827.4... = 7627.433388$$

$$\underline{\hspace{10em} 7627.4 \hspace{10em}} \text{ m}^2$$

(3)

(Total for Question 13 is 6 marks)



14 The diameter of Lenny's bike wheel is 62 cm.

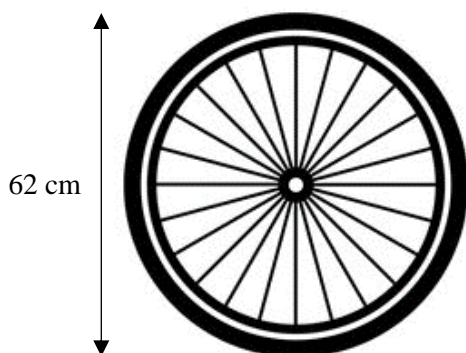

Lenny rides his bike 800 metres.

Work out how many complete revolutions his bike wheel will complete.

$$\pi \times 62 = 194.7787445 \text{ cm} \quad \swarrow \text{(one revolution)}$$

$$800 \text{ m} \overset{\times 100}{=} 80000 \text{ cm}$$

$$80000 \div 194.7\dots = 410.7224338$$

410

(Total for Question 14 is 4 marks)



15 Two touching circles fit exactly inside this rectangle.

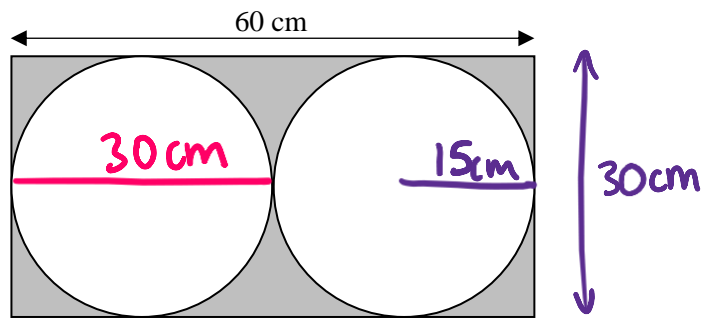

- (a) Work out the circumference of one of the circles.
Give your answer to the nearest centimetre.

$$\pi \times 30 = 94.24777961 \text{ cm}$$

94
 cm
 (2)

- (b) Work out the area of the shaded region.
Give your answer to 1 decimal place.

$$\text{Rectangle : } 60 \times 30 = 1800$$

$$\text{Circle : } \pi \times 15^2 = 706.8583471$$

$$2 \text{ Circles : } 706.8... \times 2 = 1413.716694$$

$$1800 - 1413.7... = 386.2833059$$

386.3
 cm²
 (4)

(Total for Question 15 is 6 marks)





16 A semicircle is cut from a square as shown.

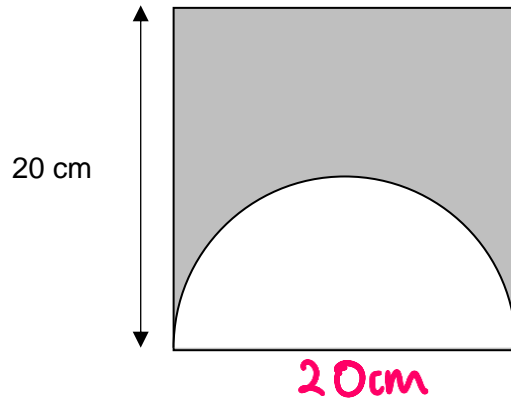

Work out the area of the shaded region.
Give your answer in terms of π

$$\text{Square: } 20 \times 20 = 400 \text{ cm}^2$$

$$\begin{aligned} \text{Semicircle: } \pi \times 10^2 &= 100\pi \\ 100\pi \div 2 &= 50\pi \end{aligned}$$

$$400 - 50\pi \text{ cm}^2$$

(Total for Question 16 is 4 marks)



17 5 congruent circles of radius 4 cm fit inside a larger circle.

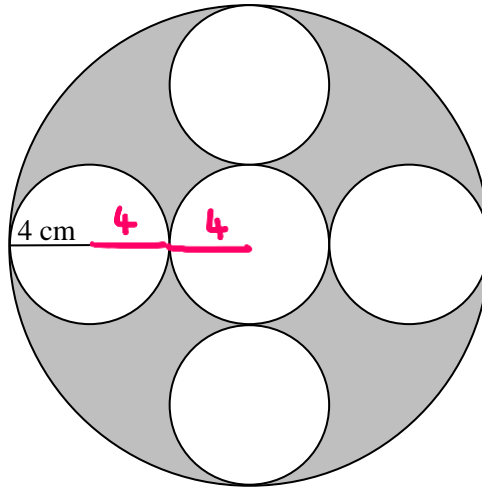

Work out the area of the shaded region.
Give your answer in terms of π

$$\begin{aligned} \text{Area of large circle} &= \pi \times 12^2 \\ &= 144\pi \end{aligned}$$

$$\begin{aligned} \text{Area of small circle} &= \pi \times 4^2 \\ &= 16\pi \end{aligned}$$

$$\begin{aligned} \text{Shaded Region} &= 144\pi - 5 \times 16\pi \\ &= 144\pi - 80\pi \end{aligned}$$

$$\underline{\underline{64\pi}} \text{ cm}^2$$

(Total for Question 17 is 4 marks)



18 A design is made by placing a semicircle on top of a square.

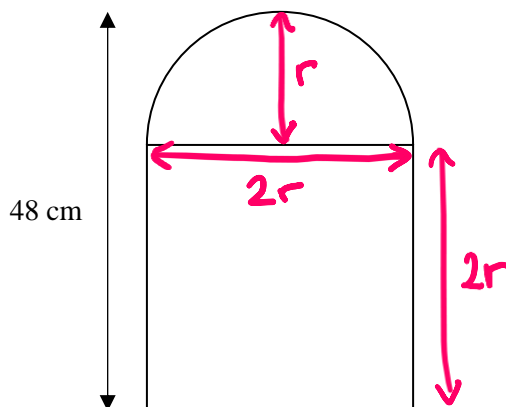

The total height of the design is 48 cm.
Work out the total area of the design.
Give your answer to 1 decimal place.

$$\div 3 \left(\begin{array}{l} 3r = 48 \\ r = 16 \end{array} \right) \div 3$$

$$\begin{array}{l} \text{radius} = 16 \\ \text{diameter} = 32 \end{array}$$

$$\begin{array}{l} \text{Square : } 32 \times 32 = 1024 \\ \text{Semicircle : } \pi \times 16^2 = 804.2477193 \\ 804.2... \div 2 = 402.1238597 \end{array}$$

$$1024 + 402.12... = 1426.12386$$

..... 1426.1 cm²

(Total for Question 18 is 4 marks)

